



غرفة صناعة الأردن  
Jordan Chamber of Industry

الرقم Ref. No. ٥٥٧/١١٤١

التاريخ Date ١٤٤١/٤/٢٥

حضرات السادة قطاع التعبئة والتغليف والورق والكرتون واللوازم المكتبية المحترمين

تحية طيبة وبعد...

ارفق لحضراتكم كتاب مدير نظام الاعتماد والتقييس ومرفقاته رقم م/عام/ 58 تاريخ 2021/02/15 والمتضمن مشروع التصويت على المواصفة القياسية الاردنية رقم 2021/2323 ايزو 2016/11950 والخاصة (بمنتجات الصفيح المقصود المسحوب على البارد) - المطلي كهربائياً بالكروم او اوكسيد الكروم والتي اعدتها اللجنة الفنية الدائمة " للحديد والفولاذ رقم (28)

ارجو العلم والاطلاع والمشاركة الفاعلة وابداء الملاحظات الفنية على المشروع اعلاه وذلك بواسطة بطاقة التصويت المرفقة وارسالها وارسالها للمهنة دانية القضاة على فاكس الغرفة رقم 4642649 او على البريد الالكتروني [danial@jci.org.jo](mailto:danial@jci.org.jo) في موعد اقصاه 2021/4/1.

وتفضلوا حضراتكم بقبول فائق الاحترام والتقدير ...

عبد الحكيم ظاظا

عضو مجلس ادارة غرفة صناعة الاردن

ممثل قطاع التعبئة والتغليف والورق والكرتون

واللوازم المكتبية



غرفة صناعة الأردن  
Jordan Chamber of Industry



962 4642649 | 962 4642649

P.O. Box 93108, Amman 11181 Jordan

[jci.org.jo](http://jci.org.jo) | [www.jci.org.jo](http://www.jci.org.jo)

؟ حسنة  
سيد محمد  
أحمد  
أحمد

الرقم م 7 عام 597  
التاريخ 03 / 07 / 1442 هـ  
الموافق 15 / 02 / 2021 م

معالي ..... الأكرم  
عطوفة ..... المحترم  
سعادة ..... المحترم

تحية طيبة وبعد،،

أرجو سيادتكم التكرم بالعلم بأن أسلوب العمل الفني المتبع في وضع المواصفات القياسية والقواعد الفنية الأردنية يقتضي تعميم مشروع التصويت على الجهات ذات العلاقة، وذلك لإبداء الرأي والتصويت عليه تمهيداً لعرضه على مجلس الإدارة لاعتماده كمواصفة قياسية أو قاعدة فنية أردنية.

لذا أرجو أن أرفق لكم طياً نسخة عن مشروع التصويت للمواصفة القياسية الأردنية ٢٠٢١/٢٣٢٣ إيضاً ٢٠١٦/١١٩٥٠ الخاصة بمنتجات حديد الصفيح المقصدر المسحوب على البارد - المطلي كهربائياً بالكروم أو أكسيد الكروم، والذي أعدته اللجنة الفنية الدائمة للحديد والفولاذ (٢٨).

يرجى التكرم بعرض هذا المشروع على الختمين لديكم وموافقتنا بردكم عليه خلال شهرين من تاريخه، وذلك باستخدام بطاقة التصويت المرفقة، علماً بأن عدم الرد خلال المدة يعتبر موافقة من قبلكم على المشروع المذكور.

وتفضلوا سيادتكم بقبول فائق الاحترام،،

القائم بأعمال مدير نظام الاعتماد والتقييس

م. لانا محمد مراشدة



المرفات:  
- مشروع التصويت.  
- بطاقة التصويت.  
- نسخة من تقرير مديرية التقييس  
- نسخة من رئيس قسم الفحص والمتابعة  
- نسخة من رئيس قسم الصناعات الهندسية  
- نسخة م. دنية المواصفة  
م ش / ع  
٢٠٢١/٢/٧

الرقم م 7 لعام 2021  
التاريخ 03/07/2021  
الموافق 15/02/2021

تعميم مشروع التصويت

عنوان المشروع: منتجات حديد الصفائح المقصد المسحوب على البارد - المطلي كهربائياً بالكروم أو أكسيد الكروم.  
سكرتير اللجنة الفنية: م. أمية الحوامدة.

قائمة الجهات التي تم التعميم عليها				
الرقم	الجهة	عنوان البريد الإلكتروني	الرقم	الجهة
١.	الجنةة العلمية للملكية	Rssinfo@rss.jo	٢.	فرقة صناعة الاردن
٣.	وزارة التربية والتعليم	Moecs@moe.gov.jo	٤.	غرفة التجارة الاردن
٥.	وزارة الشباب	Web@moy.gov.jo	٦.	فرقة صناعة عمان
٧.	وزارة الداخلية	Info@moi.gov.jo	٨.	غرفة التجارة عمان
٩.	مديرية الامن العام	Psd@psd.gov.jo	١٠.	الجامعة الاردنية
١١.	الديزينة العامة للدفاع المدني	Internet@cdd.gov.jo	١٢.	الجامعة الهاشمية
١٣.	المجلس الاعلى للعلوم والتكنولوجيا	Info-sg@hcst.gov.jo	١٤.	جامعة البلقاء التطبيقية - كلية الهندسة التكنولوجية
١٥.	المجلس الصحي الاعلى	Hhealth@hhc.gov.jo	١٦.	جامعة اليرموك
١٧.	مركز الحسين للسرطان	Info@khcc.jo	١٨.	الجمعية الكيميائية الأردنية
١٩.	دائرة النوازم العامة	Gsd@gsd.gov.jo	٢٠.	الجمعية الوطنية لحماية المستثمرين
٢١.	دائرة المطامير الحكومية	Gtd@gtd.gov.jo	٢٢.	الجمعية الوطنية لحماية المستهلك
٢٣.	جامعة علوم والتكنولوجيا	Public@just.edu.jo	٢٤.	مؤسسة التدريب المهني
٢٥.	لقابة المهندسين	Info@jea.org.jo Ccr@jea.org.jo	٢٦.	وزارة الصناعة والتجارة والتموين
٢٧.	لقابة الاطباء	Info@jma.org.jo	٢٨.	الخبرات العسكرية لمراقبة الجودة

القائم بأعمال مدير نظام الاعتماد والتقييم

م. لانا محقق مراجعة

نظام / مدير مديرية التقييم  
نظام / رئيس قسم اللحص والتأهية  
نظام / رئيس قسم الصناعات الهندسية  
نظام / أمية الحوامدة  
م / م / ع  
٢٠٢١/٢/٧

المكتب الإلكتروني للمتابعة

هاتف: ٥٣٠١٢٢٥، ٦٩٦٢٦، فاكس: ٥٣٠١٢٤٩، ٦٩٦٢٦، ص.ب. ٩٤١٢٨٧ عمان ١١١٩٤ الأردن الموقع الإلكتروني: www.jasmo.gov.jo - www.su.gov.jo

مؤسسة المواصفات والمقاييس الأردنية  
بطاقة تصويت

رقم المشروع: ع ت ٢٠٢١/٢٣٢٣ إيزو ٢٠١٦/١١٩٥٠		منتجات حديد الصفيح المقصود المسحوب على البارد - المطلي كهربائياً بالكروم أو أكسيد الكروم				
اسم اللجنة الفنية: اللجنة الفنية الدائمة للحديد والفلاد (٢٨)		سكرتير اللجنة الفنية: م. أمية للحوامة				
تاريخ التصميم: ٢٠٢١/٠٢/٠٧		آخر موعد للرد: ٢٠٢١/٠٤/٠٧				
الرقم	نوع للملاحظة			الملاحظة *	التعديل المقترح	رأي اللجنة الفنية
	عامة	فنية	هيكلية وصياغية			
النتيجة النهائية للتصويت:						
<input type="checkbox"/> موافقة (لا توجد ملاحظات).						
<input type="checkbox"/> موافقة مع الملاحظات المرفقة، والتي يمكن الأخذ بها أو تجاوزها حسب الاقتضاء.						
<input type="checkbox"/> عدم موافقة للأسباب الفنية المرفقة، والتي عند زوالها ينقلب التصويت إلى موافقة.						
يرجى تزويدنا بالمراجع التي اعتمد عليها في حالة وجود ملاحظات.						
الجهة القائمة بالتصويت:					التاريخ:	
اسم الشخص المسؤول:						



مديرية التقييس	
رقم المشروع: ع ت ٢٠٢١/٢٣٢٣ /نزو ٢٠١٦/١١٩٥٠	تاريخ التعميم: ٢٠٢١/٠٢/٠٧ م
اسم اللجنة الفنية: اللجنة الفنية الدائمة للحديد وال فولاد (٢٨)	آخر موعد للرد: ٢٠٢١/٠٤/٠٧ م
سكرتير اللجنة الفنية: م. أمية الحوامدة	

مشروع تصويت

(تبني معائن)

منتجات حديد الصفيح المقصود المسحوب على البارد – المطلي كهربائياً بالكروم  
أو أكسيد الكروم

*Cold-reduced tinmill products – Electrolytic chromium /chromium oxide-coated  
steel*

هذه الوثيقة مشروع تصويت تم توزيعه لإبداء الرأي والملاحظات. لذلك فهو عرضة للتغير والتعديل، ولا يجوز الرجوع إليه كمواصفة قياسية أردنية إلا بعد اعتماده من قبل مجلس الإدارة.



DJS 2323:2021 ISO 11950:2016

First edition

ع ت ٢٠٢١/٢٣٢٣ إيؤ ٢٠١٦/١١٩٥٠

الإصدار الأول

## مشروع تصويت

(تتبي مائل)

منتجات حديد الصفيح المقصدر المسحوب على البارد - المطلي كهربائياً بالكروم أو أكسيد  
الكروم

*Cold-reduced tinmill products - Electrolytic chromium /chromium oxide-coated  
steel*

---

مؤسسة المواصفات والمقاييس

المملكة الأردنية الهاشمية

هذه الوثيقة مشروع تصويت تم توزيعه لإبداء الرأي والملاحظات. لذلك فهو عرضة للتغيير والتبديل، ولا يجوز الرجوع إليه  
كمواصفة قياسية أردنية إلا بعد اعتماده من قبل مجلس الإدارة.

## Contents

### Foreword

1- Scope.....	1
2- Normative references.....	1
3- Terms and definitions.....	1
4- General technical delivery condition.....	4
5- Classification.....	4
6- Information to be supplied by the purchaser.....	4
7- Manufacturing features.....	5
8- Chromium/chromium in oxide coating mass.....	6
9- Mechanical properties.....	6
10- Tolerances on dimensions and shape.....	7
11- Joint within a coil.....	9
12- Sampling.....	10
13- Test method.....	10
14- Retests.....	14
15- Inspection document.....	14
16- Dispatch and packaging.....	14
AnnexA (normative) Hardness requirements for ECCS.....	16
AnnexB (normative) Tensile property requirements for ECCS.....	17
AnnexC (informative) Steel types.....	18
AnnexD (informative) Springback test for routine determination of proof strength for ECCS.....	19
AnnexE (normative) Methods for the determination of metallic chromium and chromium in the oxides on the surface of electrolytic chromium/chromium oxide-coated steel.....	20
AnnexF (normative) Rockwell HRI 5Tm values and their HR30Tm equivalents.....	25
AnnexG (informative) Bibliography.....	26

### Figures

Figure 1 - Edge camber of coil.....	8
Figure 2 - Edge camber of sheet.....	8
Figure 3 - Out-of-squareness of sheet.....	9
Figure 4 - Joint overlap.....	10
Figure 5 - Location of test pieces.....	11
Figure 6 - Edge wave.....	12
Figure 7 - Longitudinal or transverse bow.....	13
Figure 8 - Definition of centre fullness.....	13
Figure 9 - Method of measuring centre fullness (direct method).....	13
Figure 10 - Method of measuring centre fullness (indirect method).....	14
Figure 11 - Direction of coil winding.....	15
Figure E. 1 - Dual-purpose sample holder showing details of construction.....	21
Figure E. 2 - Electro-stripping of chromium metal using the dual-purpose cell.....	23
Figure E. 3 - Electro-circuit for stripping chromium metal.....	23

### Tables

Table 1 - Typical finishes for blackplate.....	5
--	---

This Jordanian Standard and JS 2324:2021 ISO 11949:2016 and JS 2322:2021 ISO 11951:2016 cancel and replace the Jordanian Standard 372 issued in 2005.

هذا القياسية مشروع تصويت تم تربيته لإبقاء الرأي والملاحظات. ذلك لغير هرضة للتغيير والتعديل، ولا يجوز الرجوع إليه كموصلة لمصلحة أردنية إلا بعد استشارة من قبل مجلس الإدارة.

Table 2 - Average chromium/chromium in oxide coating mass .....	6
Table A-1 - Hardness values (HR30Tm) for single cold-reduced ECCS.....	16
Table A-2 - Hardness values (HR30Tm) for double cold-reduced ECCS .....	16
Table B-1 - Tensile properties for blackplate.....	17
Table F-1 - Rockwell HR15Tm values and their HR30Tm equivalents .....	25

This Jordanian Standard and JS 2324:2021 ISO 11949:2016 and JS 2322:2021 ISO 11951:2016 cancel and replace the Jordanian Standard 372 issued in 2005.

هذه الوثيقة مشروع تصويت تم تذييمه لإجراء الرأي والملاحظات. انتك أهر عرضة للتغيير والبدال، ولا يجوز الرجوع إليه كمراسلة فورية أردنية إلا بعد اعتماد من قبل مجلس الإدارة.



## Foreword

Jordan Standards and Metrology Organization is the national standardization body in Jordan. The work of preparing Jordanian Standards is normally carried out by technical committees composed of the interested parties, which are involved in the scope of the standard. All the interested parties have the right to comment on the draft Jordanian Standard during the inquiry stage, taking into consideration the importance of harmonizing Jordanian Standards with the international, regional or national standards (as much as possible) for the purpose of eliminating technical barriers to trade and facilitating the international trade.

Jordanian Standards are drafted in accordance with the rules given in the Jordanian Directive 1-2/2005, part 2: Rules for the structure and drafting of Jordanian Standards related to standardization department.<sup>\*)</sup>

The permanent technical committee for Steel and Iron (28) has studied the prepared project of the Jordanian Standard 2323:2021 ISO11950:2016 related to Cold-reduced tinmill products – Electrolytic chromium/chromium oxide-coated steel and the following Jordanian Standard 372:2005, Iron and steel products – Cold-reduced black plate and electrolytic tinplate.

Where it has recommended to withdraw the above mentioned Jordanian Standards and to approve the project as a Jordanian Standard 2323:2021 ISO11950:2016, according to article (12) of Standards and Metrology Law No. (22) for the year 2000 and it's amendments.

For the purposes of this Jordanian Standard, the following editorial changes have been made:

- Substitution of "this International Standard" by "this Jordanian Standard".
- The introduction has been omitted because it does not comply with the Jordanian standard.
- Addition word "clause" for each clause number.
- Inclusion of bibliography in an informative annex G.

---

<sup>\*)</sup> under amendment

هذا الترتيب مشروعي لم يدرج فيه أي تعديلات أو إضافات. لذلك لم يدرج في هذا الترتيب أي تعديلات أو إضافات. ولا يجوز الرجوع إليه كمرجع فنية أردنية إلا بعد إقراره من قبل مجلس الإدارة.

## Cold-reduced tinmill products – Electrolytic chromium/chromium oxide-coated steel

### 1- Scope

This Jordanian Standard specifies requirements for single and double cold-reduced electrolytic chromium/chromium oxide-coated steel (ECCS) in the form of sheets or coils.

Single cold-reduced ECCS is generally specified in nominal thicknesses that are multiples of 0,005 mm, from 0,150 mm up to and including 0,600 mm. Double cold-reduced ECCS is generally specified in nominal thicknesses that are multiples of 0,005 mm, from 0,100 mm up to and including 0,360 mm.

This Jordanian Standard applies to coils and sheets cut from coils in nominal minimum rolling widths of 600 mm<sup>1)</sup>.

### 2- Normative references

The following referenced documents are indispensable for the application of this document. For dated references, only the edition cited applies. For undated references, the latest edition of the referenced document (including any amendments) applies. Indexes for published standard can be found in JSMO's library.

- ISO 404, Steel and steel products — General technical delivery requirements.
- ISO 4288, Geometrical Product Specifications (GPS) — Surface texture: Profile method — Rules and procedures for the assessment of surface texture.
- ISO 6508-1, Metallic materials — Rockwell hardness test — Part 1: Test method.
- ISO 6892-1<sup>2)</sup>, Metallic materials — Tensile testing — Part 1: Method of test at room temperature.
- ISO 10474, Steel and steel products — Inspection documents.

### 3- Terms and definitions

For the purposes of this document, the following terms and definitions apply.

#### 3-1

##### blackplate

cold-reduced low-carbon mild steel, applied for manufacturing ECCS

Note: See JS 2322 ISO 11951<sup>3)</sup>.<sup>[1]</sup>

#### 3-2

##### electrolytic chromium/chromium oxide-coated steel

##### ECCS

cold-reduced low-carbon mild steel sheet or coil, electrolytically treated to produce on both surfaces a duplex film of metallic chromium adjacent to the steel substrate with a top layer of hydrated chromium oxide or hydroxide

#### 3-3

##### single cold-reduced

description of product in which the blackplate has been reduced to the desired thickness in a cold-reduction mill and subsequently annealed and temper rolled

<sup>1)</sup> Nominal minimum rolling widths of 500 mm may be applied by agreement between the purchaser and the manufacturer.

<sup>2)</sup> To be published (Revision of ISO 6892-1:2009)

<sup>3)</sup> under amendment

**3-4**

**double cold-reduced**

description of product in which the blackplate has had a second major reduction after annealing

**3-5**

**standard grade ECCS sheet**

product in sheet form which is confirmed to be suitable, under normal conditions of storage, for established lacquering and printing over the entire sheet and is

a) free from surface imperfections which render the material unsuitable for the intended use, and

b) free from damage which render the material unsuitable for the intended use

Note: The standard material is compliant with the requirements as specified in this Jordanian Standard.

**3-6**

**batch annealed**

**box annealed**

**BA**

annealed by the process in which the cold-reduced strip is annealed in coil form, within a protective atmosphere, for a predetermined time-temperature cycle

**3-7**

**continuously annealed**

**CA**

annealed by the process in which cold-reduced coils are unwound and annealed in strip form within a protective atmosphere

**3-8**

**finish**

appearance of the surface of ECCS, governed by the surface roughness,  $R_a$ , of the steel base which results from controlled preparation of the work rolls during the final stages of rolling

**3-8-1**

**smooth finish**

finish of blackplate resulting from the use of temper-mill work rolls that have been ground to a low roughness

Note: This finish is used for the production of bright finish ECCS.

**3-8-2**

**bright finish**

finish on ECCS using the smooth finish blackplate

**3-8-3**

**stone finish**

finish characterized by a directional pattern, resulting from the use of final-mill work rolls that have been ground to a higher level of roughness than those used for the smooth finish

**3-8-4**

**matt finish**

finish resulting from the use of temper-mill work rolls with dull surface textured by shot blast, electro discharge texturing (EDT), electron beam texturing (EBT) or another suitable method

**3-9**

**coil**

rolled flat strip product which is wound into regularly superimposed laps so as to form a coil with almost flat sides

**3-10**

**longitudinal bow**

**line bow**

residual curvature in the strip remaining along the direction of rolling

**transverse bow****cross bow**

mode of curvature in the sheet such that the distance between its edges parallel to the direction of rolling is less than the sheet width

3-11

**centre fullness****centre buckle****full centre**

intermittent vertical displacement or wave in the strip occurring other than at the edges

.Note: See Figure 8.

3-12

**edge wave**

intermittent vertical displacement occurring at the strip edge when the strip is laid on a flat surface

3-13

**feather edge****transverse thickness profile**

variation in thickness, characterized by a reduction in thickness close to the edges, at right angles to the direction of rolling

3-14

**edge camber**

deviation of edge of coil/sheet from a straight line forming its chord

3-15

**burr**

metal displaced beyond the plane of the surface of the strip by shearing action

3-16

**rolling width**

width of the rolled strip perpendicular to the direction of rolling

3-17

**pallet**

base platform on which a coil is placed to facilitate ready transportation

3-18

**stillage platform**

base platform on which sheets are stacked to facilitate packing and ready transportation

3-19

**consignment**

quantity of material of the same specification made available for dispatch at the same time

3-20

**bulk package****bulk**

packaging unit comprising a stillage platform, the sheets and packaging material

3-21

**line inspection**

final inspection of the finished product performed by instruments and/or visual examination at normal production-line speeds

3-22

**anvil effect**

effect that a hard anvil can produce on the numerical hardness value obtained when a hardness test is performed on very thin sheet supported on such an anvil

#### 4- General technical delivery condition

In cases where the technical delivery condition is not specified in this Jordanian Standard, then ISO 404 shall apply.

#### 5- Classification

Steel grades for this Jordanian Standard are generally classified as non-alloy quality steels.

#### 6- Information to be supplied by the purchaser

##### 6-1 Designation

For the purposes of this Jordanian Standard, ECCS is designated in terms of a steel grade classification based either on the Rockwell HR30Tm hardness values or on the tensile properties. For the hardness requirements, the steel grade designations are given in Table A.1 for single cold-reduced ECCS and in Table A.2 for double cold-reduced ECCS. For the tensile properties requirements, the steel grade designations are given in Table B.1.

ECCS covered by this Jordanian Standard shall be designated by the following characteristics in the given sequence:

- a) a reference to this Jordanian Standard, i.e. JS 2232 ISO 11950;
- b) the steel grade designation in accordance with Table A-1, Table A-2 or Table B-1;
- c) the type of annealing used by the manufacturer (see clause 7-2);
- d) the type of finish (see clause 7-3);
- e) the dimensions, in millimetres:
  - for coils, thickness × width;
  - for sheets, thickness × width × length.

By agreement, the symbol "× C" after width may be designated for coils.

By agreement, the symbol "w" may be designated after the number for the width to indicate that the number is the dimension perpendicular to the direction of rolling.

Examples:

i) Single cold-reduced ECCS sheet, in accordance with this Jordanian Standard, steel grade T61, continuously annealed (CA), stone finish, with a thickness of 0,220 mm, a width of 800 mm and a length of 900 mm shall be designated:

JS 2323 ISO 11950 - T61 CA - stone - 0,220 × 800 × 900

ii) Double cold-reduced ECCS coil, in accordance with this Jordanian Standard, steel grade T75, continuously annealed (CA), stone finish, with a thickness of 0,180 mm and a width of 750 mm shall be designated:

JS 2323 ISO 11950 - T75 CA - stone - 0,180 × 750

iii) ECCS coil, in accordance with this Jordanian Standard, steel grade TH415, continuously annealed (CA), stone finish (ST), with a thickness of 0,200 mm, a width of 750 mm shall be designated:

JS 2323 ISO 11950 - TH415 CA - ST - 0,200 × 750 × C

iv) ECCS sheet, in accordance with this Jordanian Standard, steel grade TS520, batch annealed (BA), stone finish, with a thickness of 0,140 mm, a dimension perpendicular to the direction of rolling of 844 mm and a length of 755 mm shall be designated:

JS 2323 ISO 11950 - TS520 BA - stone - 0,140 × 844w × 755

##### 6-2 Mandatory information

The following information shall be given in the enquiry and order to assist the manufacturer in supplying the correct material:

- a) the designation as given in clause 6-1;
- b) the quantity, expressed on an area or mass basis, e.g. 50 tons of sheets, 100 tons of coils;

- c) the minimum and the maximum coil weight, the minimum and the maximum coil outer diameter, the coil internal diameter, the core vertical or horizontal and the direction of winding (see clause 16-1);
- d) the maximum weight of bulk package;
- e) other inspection document than that specified by the manufacturer (see Clause 15);
- f) end use;
- g) any further special requirements.

Note: Appropriate steel grade is suitable for shaping operations such as stamping, drawing, folding, beading and bending and assembly work such as joint forming, soldering and welding. The end use is important when the steel grade is selected.

### 6-3 Options

In addition to the information in clause 6-2, the purchaser may wish to provide additional information to the manufacturer to ensure that the order requirements are consistent with the end use of the product.

The purchaser shall inform the manufacturer of any modifications to his/her fabrication operations that will significantly affect the way in which the ECCS is used.

Note: When ordering cold-reduced ECCS, the purpose of manufacture for which the material is intended is generally stated. When double cold-reduced ECCS is used for built-up can bodies, the rolling direction is around the circumference of the can so as to minimize the hazard of flange cracking. In such cases, the direction of rolling is clearly designated on the contract.

## 7- Manufacturing features

### 7-1 Manufacture

Continuously cast, fully-killed steel is applied except when otherwise specified. The examples of the steel types of ECCS are shown in Annex C.

The steel type of ECCS shall be designed to secure food safety when ECCS is used for food application. The purchasers should be aware of existing national regulations which may impose limitations on some elements.

The manufacturing method of ECCS is left to the discretion of the manufacturer and is not specified in this Jordanian Standard.

### 7-2 Annealing

Annealing of ECCS shall be either batch annealing (BA) or continuous annealing (CA) and shall be specified by the purchaser at the time of enquiry and order.

### 7-3 Finish

ECCS is usually available in the finishes as indicated in Table 1. The type of finish is designated either by the ECCS finish or the code shown in Table 1.

Table 1 - Typical finishes for ECCS

ECCS finish	Code <sup>a)</sup>	Blackplate	
		Finish	Surface roughness <sup>b),c)</sup> Ra µm
Bright	BT	Smooth	≤ 0,35
Fine stone	FS	Fine stone	0,25 – 0,45
Stone	ST	Stone	0,35 – 0,60
Matt	MM	Matt	≥ 0,90

<sup>a)</sup> By agreement between the purchaser and the manufacturer, another code system may be applied.

<sup>b)</sup> Values of surface roughness in this table are not mandatory. The values are given for reference in order to classify the finishes.

<sup>c)</sup> The measurement of surface roughness is in accordance with ISO 4288.

Note 1: Special surface finishes are available by agreement at the time of ordering.

Note 2: Double cold-reduced ECCS is usually supplied with a stone finish.

#### 7-4 Oiling

Under normal conditions of transport and storage, ECCS shall be suitable for surface treatments, such as established lacquering and printing operations.

ECCS coils and sheets are supplied with an oil coating. The oil shall be one that is recognized (i.e. by the relevant national or Jordanian authority) as being suitable for food packaging. Unless otherwise agreed at the time of ordering, the kind of oil is at the discretion of the manufacturer.

Note: For the oil, dioctyl sebacate (DOS) is usually used.

#### 7-5 Imperfections

##### 7-5-1 Coils

The manufacturer is expected to employ his/her normal quality control and line inspection procedures to ensure that the ECCS manufactured is in accordance with the requirements of this Jordanian Standard.

However, the production of ECCS coils in continuous-strip mill operations does not afford the opportunity for removal of all ECCS that do not comply with the requirements of this Jordanian Standard.

At the time of shearing, sheets not conforming to the standard grade shall be set aside by the purchaser or his/her agent.

The quantity of sheets complying with this Jordanian Standard shall be at least 90 % of any one coil.

List items a) and b) in clause 3-5 cannot be verified by specific tests. Accordingly, those items are recommended to be the subject of a special agreement between the purchaser and the manufacturer. In processing ECCS coil, when the purchaser (or his/her agent) encounters recurring imperfections which in his/her opinion seem excessive, it is essential, where practicable, that he/she stops processing the coil and advises the manufacturer.

The purchaser is expected to have adequate handling, roller levelling and shearing equipment and inspection facilities to segregate the sheets not conforming to the standard grade and to take reasonable care during these operations.

##### 7-5-2 Sheets

Sheets shall not contain any imperfections as defined in clause 3-5.

### 8- Chromium/chromium in oxide coating mass

The minimum and maximum average values of coating mass of the samples selected in accordance with Clause 12 shall be as given in Table 2, when tested as described in clause 13-1.

Table 2 - Average chromium/chromium in oxide coating mass

Form of chromium	Average coating mass on each surface mg/m <sup>2</sup>	
	Minimum	Maximum
Total chromium	50	185
Chromium in oxide	5	35

### 9- Mechanical properties

#### 9-1 General

For the purposes of this Jordanian Standard, ECCS is classified into steel grades based on either Rockwell HR30Tm hardness values or tensile properties. The purchaser shall indicate the

specification either by hardness requirement or by tensile properties requirement, but not for both, when ordering the material.

When ordering the material for applications such as drawn cans, DWI cans, twist off caps, etc., it is recommended to indicate the specification according to the tensile property requirement.

Other mechanical properties might significantly influence the performance of ECCS in processing, and the subsequent intended end use might vary depending on the steel type and the methods of casting, annealing and temper rolling employed.

At the time of enquiry and order, it shall be agreed that properties of steel grade are to be verified either by the hardness test or by the tensile test.

#### 9-2 Hardness requirement

The hardness values for ECCS shall be as given in Table A.1 and Table A.2, when tested as described in clause 13-2.

#### 9-3 Tensile property requirement

The proof strength,  $R_{p0.2}$ , for ECCS shall be as given in Table B.1, when tested as described in clause 13-3.

For routine testing, the proof strength may be determined using the springback test as described in Annex D. However, in cases of dispute, the method described in clause 13-3 shall be applied.

## 10- Tolerances on dimensions and shape

### 10-1 General

Tolerances on dimensions (i.e. thickness, width and length) and shape (i.e. edge camber, out-of-squareness and flatness) are specified in clause 10-2 to 10-7, together with appropriate methods of measurement.

### 10-2 Thickness and feather edge

#### 10-2-1 Thickness

Nominal thickness shall be a multiple of 0,005 mm. Nominal thickness other than multiple of 0,005 mm may be specified by agreement between the purchaser and the manufacturer. Thickness out of the nominal thickness range may be specified by agreement between the purchaser and the manufacturer.

The thickness of ECCS shall not deviate from the ordered nominal thickness by more than +5, -8 % at any point except within 10 mm from the trimmed-edge.

The thickness shall be measured using a hand-operated, spring-loaded micrometer to an accuracy of 0,001 mm.

It is recommended that the micrometer should have a ball-ended shank and a curved-surface base anvil.

#### 10-2-2 Feather edge

For both sheet and coil, the thickness when measured at a distance of 10 mm from the mill trimmed edge shall not deviate from the actual centre thickness by more than -6 %.

### 10-3 Width

The width of ECCS shall be measured to the nearest 0,5 mm, at right angles to the direction of rolling.

For the products of this Jordanian Standard which are delivered with trimmed-edge, the measured width shall not deviate from the ordered width by more than +3, -0 mm.

### 10-4 Length

#### 10-4-1 Length of coil

The difference between the actual length and the manufacturer's indicated length, measured on any single coil, shall not exceed by more than  $\pm 3$  %, unless otherwise agreed.

#### 10-4-2 Length of sheet

The length of sheet shall be measured to the nearest 0,5 mm. The measured length shall not deviate by more than +3, -0 mm from the ordered length.



**10-5 Edge camber**

Edge camber is the maximum deviation (in the plane of the sheet) of an edge from a straight line forming a chord to its extremities (see Figure 1 and Figure 2).

The edge camber, E, expressed as a percentage of the chord length, is calculated using Formula (1):

$$E = \frac{D}{L} \times 100 \tag{1}$$

where

D: is the deviation from a straight line, in millimetres;

L: is the length of chord, in millimetres.

For coils, the edge camber, measured over a distance (chord length) of 1 000 mm, shall not exceed 0,1 % (i.e. 1 mm).

Dimensions in millimetres

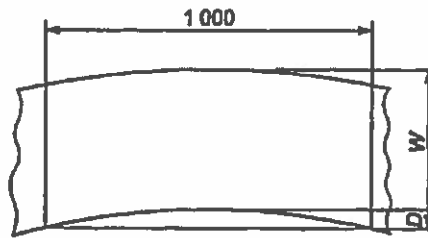

Key  
W: width  
D : deviation from a straight line

**Figure 1 - Edge camber of coil**

For sheets, the edge camber, measured over a chord length, shall not exceed 0,1 %.

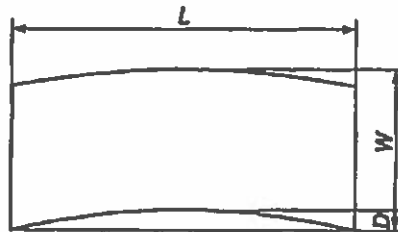

Key  
L : length of chord  
W : width  
D : deviation from a straight line

**Figure 2 - Edge camber of sheet**

**10-6 Out-of-squareness of sheet**

Out-of-squareness is the deviation of an edge from a straight line drawn at a right angle to the other edge of the sheet, touching one corner and extending to the opposite edge (see Figure 3).

The out-of-squareness, O<sub>s</sub>, expressed as a percentage, is calculated using Formula (2):

$$O_s = \frac{A}{B} \times 100 \tag{2}$$

where

A: is the deviation;

B: is the length or width of the sheet measured at a right angle to an edge.

For each sheet in the sample, the out-of-squareness shall not exceed 0,20 %.

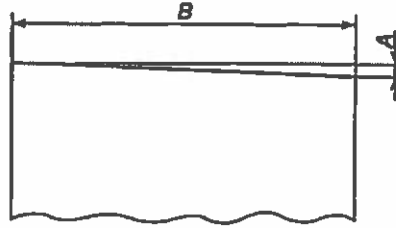

#### Key

A: deviation

B: length or width of the sheet measured at a right angle to an edge

Figure 3 - Out-of-squareness of sheet

### 10-7 Flatness

#### 10-7-1 Edge wave

The height of edge wave,  $h_{ew}$ , at any point shall not exceed 2,5 mm, when tested as described in clause 13-4-2. No more than six waves in excess of 1,5 mm shall be present over a cut length of 1 m for coil or proportional for sheet.

#### 10-7-2 Longitudinal and transverse bow

Bow may be either convex or concave face uppermost on the bulk package. The normal convention is to express convex bow uppermost as a positive (+) value and concave bow as a negative (-) value.

The individual values of both longitudinal and transverse bow in levelled condition shall not exceed 30 mm, when tested as described in clause 13-4-3. Where both convex and concave bow are present in the same coil, the sum of the maximum values of each, ignoring the sign ( $\pm$ ), shall not exceed 30 mm. In case of unlevelled sheet from coil before cutting, the requirement of bow may be agreed between the purchaser and the manufacturer.

#### 10-7-3 Centre fullness

Centre fullness shall be determined by either the direct method as described in clause 13-4-4-1 or the indirect method as described in clause 13-4-4-2. The selection of the method is at the discretion of the manufacturer. In case of the direct method, the height of centre fullness,  $h_{cf}$ , shall not exceed 5 mm when tested as described in clause 13-4-4-1. In case of the indirect method, the height of centre fullness,  $h_{if}$ , shall not exceed 9 mm when tested as described in clause 13-4-4-2.

Note: Centre fullness is not clearly visible in a coil but usually becomes apparent during either printing or slitting.

## 11- Joint within a coil

### 11-1 General

The manufacturer shall ensure continuity of the coils within the limits of the lengths ordered, if necessary, by means of electrically welded joints made after cold reduction. Requirements relating to the numbers, locations and dimensions of the joints permitted within a coil are given in clause 11-2 to 11-4.

### 11-2 Number of joint

The number of joints in a coil shall not exceed three in lengths of 10 000 m.

### 11-3 Location of joint

The location of each joint in a coil shall be indicated clearly.

The location of each joint may be indicated, for example, by the insertion of a piece of non-rigid material and punched holes. However, alternative methods may be agreed between the purchaser and the manufacturer at the time of enquiry and order.

#### 11-4 Dimension of joint

##### 11-4-1 Thickness

The total thickness of any joint shall not exceed three times the nominal thickness of the material forming the joint.

##### 11-4-2 Overlap

In any lap joint, the total length of overlap shall not exceed 10 mm. The free overlap shall not exceed 5 mm (see Figure 4).

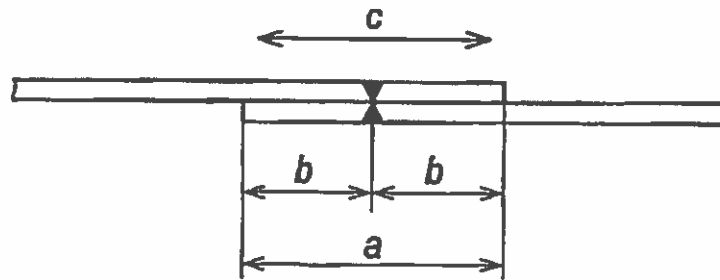

#### Key

a:total length of overlap

b:free overlap

c:direction of rolling

Figure 4 - Joint overlap

#### 12- Sampling

For certifying the quality of product, the manufacturer shall take samples according to Figure 5 and carry out test. One sheet for test specimen shall be taken for every 30 tons or less and remainder thereof of the same properties, i.e. steel grade, dimensions and coating mass.

#### 13- Test method

##### 13-1 Chromium/chromium in oxide coating mass

##### 13-1-1 Test piece

From each sheet selected in accordance with Clause 12, four discs shall be taken from each of the three sets of positions marked X on Figure 5. The edge test pieces shall be taken not less than 25 mm from the edges of the sheet. A test piece shall be a disc or a square having an area of approximately 2 500 mm<sup>2</sup>. However, in the case of the fluorescent X-ray spectrometric method, the irradiation area shall be 314 mm<sup>2</sup> or over.

When applying the method described in Annex E, two of the four discs from each position shall be used for separate determinations of the masses of chromium in the metallic chromium layer and the chromium oxide layer on one surface of the sheet and the other two discs shall be used for the corresponding determinations on the other surface.

Dimensions in millimetres

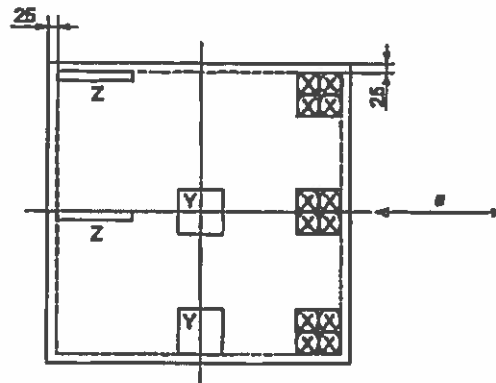
**Key**

X: test pieces for the coating mass

Y: test pieces for hardness

Z: test pieces for tensile test

a: direction of rolling

**Figure 5 - Location of test pieces****13-1-2 Method of determination**

The masses of metallic chromium and chromium in oxides shall be expressed, in milligrams per square metre, to the nearest  $1 \text{ mg/m}^2$ .

For routine quality control purposes, the coating masses may be determined by any of the recognized and acceptable analytical and instrumental methods. In cases of dispute, the methods described in Annex E shall be the referee method.

The test shall be carried out using the untreated material, in the as-produced state.

**13-2 Hardness test****13-2-1 Test piece**

The hardness tests shall be carried out prior to lacquering or printing.

From each of the sample sheets obtained in accordance with Clause 12, take two test pieces from the positions marked Y on Figure 5.

Before carrying out the hardness tests in accordance with clause 13-2-2, artificially age the test pieces at  $200 \text{ }^\circ\text{C}$  for 20 min without removing the chromium/chromium oxide coating. The artificial aging may not be necessary for non-aging materials.

When necessary, the surface shall be finished with fine emery paper.

**13-2-2 Test method**

Determine the Rockwell HR30Tm indentation hardness either

- directly, in accordance with ISO 6508-1, or
- indirectly, on relatively thin sheets (e.g. 0,22 mm and thinner), by determining the HR15Tm hardness in accordance with ISO 6508-1 and then converting the HR15Tm values to HR30Tm values using Annex F.

By agreement, the hardness may be determined either by HR30Tm or HR15Tm for the sample thickness between 0,20 mm and 0,22 mm.

Make three hardness measurements on each of the test pieces taken in accordance with clause 13-2-1. Calculate the representative hardness for the consignment as the arithmetic mean of all the hardness measurements on all the sample sheets taken from the consignment.

To measure the indentation hardness, use a Rockwell superficial hardness testing machine, employing the 30Tm or 15Tm scales specified in ISO 6508-1 with a hardened steel ball indenter, as appropriate.

Avoid testing near the edges of the test pieces because of a possible cantilever effect.

### 13-3 Tensile test

#### 13-3-1 Test piece

For each sheet selected in accordance with Clause 12, cut two rectangular test pieces with the direction of rolling parallel to the length of the test piece, at the position marked Z on Figure 5. Ensure that the edge test pieces clear the edges of the sheet by a minimum of 25 mm. Before carrying out the tensile test described in clause 13-3-2, artificially age the test pieces at 200 °C for 20 min without removing the chromium/chromium oxide coating. The artificial aging may not be necessary for non-aging materials.

#### 13-3-2 Test method

Determine the 0,2 % proof strength as described in ISO 6892-1 using the conditions specified in ISO 6892-1:—, Annex B for thin products.

Carry out one test on each of the test pieces selected in accordance with clause 13-3-1, i.e. two tests per sheet selected.

Calculate the representative proof strength for the consignment as the arithmetic mean of all the results on all the sample sheets taken from the consignment.

### 13-4 Flatness test

#### 13-4-1 General

The method of measuring flatness is at the discretion of the manufacturer. In cases of dispute, the following method shall be applied as a referee method.

#### 13-4-2 Edge wave

Each sample shall be laid on a flat horizontal surface which is larger than the sample itself. The height of edge wave,  $h_{ew}$ , shall be given as the feeler gauge diameter that just fits under the wave at the edge of the sample.

Heights of edge wave,  $h_{ew}$ , shall be determined by using feeler gauges of standard diameters in increments of 0,25 mm (Figure 6).

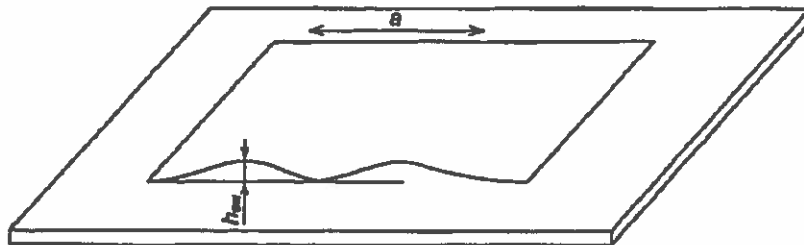

#### Key

$h_{ew}$ :edge wave

$a$  :direction of rolling

Figure 6 - Edge wave

#### 13-4-3 Longitudinal or transverse bow

The maximum value of longitudinal or transverse bow shall be determined by hanging the sample from one horizontal edge against a rigid vertical surface, noting whether the upper or lower surface is against the vertical surface, so that the bow causes the bottom edge of the sample to stand away from that surface. When selecting the sample, it is necessary to identify the outer and inner face of the coil.

The sample shall be evenly supported along the top to a depth not exceeding 25 mm from the edge. The maximum distance, the bottom edge stands away from the vertical (value  $a$  on Figure 7), is

measured with a steel ruler to the nearest 1 mm and recorded with the appropriate plus or minus sign indicating convex or concave bow, respectively.

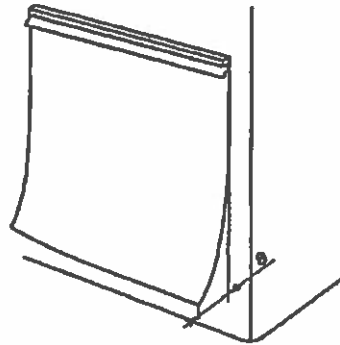

Key

a: maximum distance between the bottom edge and the vertical

Figure 7 - Longitudinal or transverse bow

13-4-4 Centre fullness

13-4-4-1 Direct method

The sample sheet shall be laid on a flat and horizontal surface which is larger than the sample. A rigid, flat and straight bar, which is supported by two rigid blocks with the same and proper height, shall be set over the sample to be approximately right above the wave of the centre fullness and parallel to the rolling direction (see Figure 9).

Both distances at the points of the top and the bottom of the wave from the lower edge of the bar shall be measured, respectively. The height of centre fullness (value  $h_{cf}$  on Figure 8) shall be determined as the difference between these two values (values  $h_2$  and  $h_1$  on Figure 9).

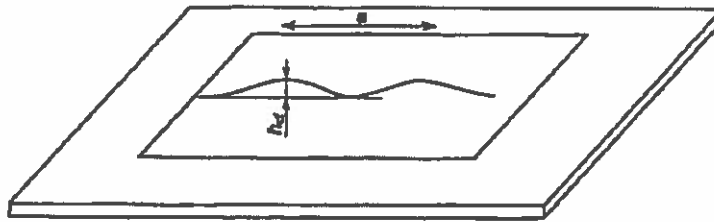

Key

$h_{cf}$ : centre fullness

a : direction of rolling

Figure 8 - Definition of centre fullness

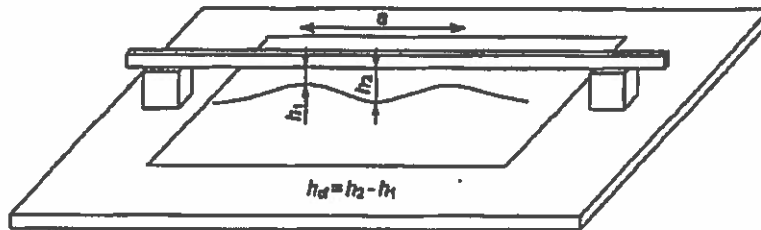

Key

a: direction of rolling

Figure 9 - Method of measuring centre fullness (direct method)

#### 13-4-4-2 Indirect method

The sample sheet shall be laid on a flat and horizontal surface which is larger than the sample. A rigid and flat board shall be placed on the centre of the sample.

The board shall be moved around the surface of the sample centre until a position giving the highest edge lift can be identified. Pressure shall then be applied to the board so as to flatten the sample in the centre and raise the edge to a maximum height. During the test, the board shall not overlap the edges to be measured.

Edge lift shall be determined by using a 9 mm diameter feeler gauge and the product is deemed out of specification when the feeler gauge fits under the edge of the sheet at the point of maximum lift (value  $h_{if}$  on Figure 10).

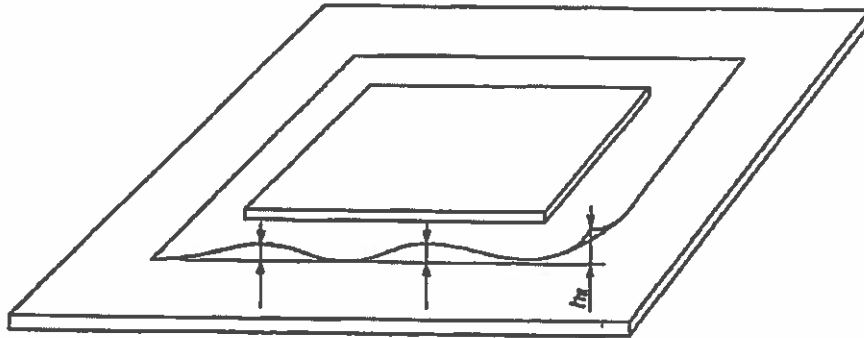

#### Key

$h_{if}$  : maximum lift of the edge

Figure 10 - Method of measuring centre fullness (indirect method)

#### 14- Retests

If any of the results obtained are unsatisfactory for coating mass and mechanical properties, the manufacturer may either withdraw the test unit or perform retest. In case of retest, the measurements for that particular property shall be repeated twice on new samples, on each occasion using the sampling specified in Clause 12. If the results on both repeated tests meet the stated requirements, the consignment represented shall be deemed to comply with this Jordanian Standard but if the results of either of the retests fail to meet the stated requirements, the consignment represented shall be deemed not to comply with this Jordanian Standard.

#### 15- Inspection document

ECCS complying with this Jordanian Standard shall be ordered and delivered with one of the inspection documents specified in ISO 10474. The type of document shall be agreed upon at the time of enquiry and order. Unless otherwise specified, the type of document shall be at the discretion of the manufacturer.

#### 16- Dispatch and packaging

##### 16-1 Coils

Coils shall be dispatched with their cores either in a vertical position or in a horizontal position. The internal diameters of the coils shall be either  $(420^{+10}_{-15})$  mm or  $(508^{+10}_{-15})$  mm.

Unless otherwise requested at the time of ordering, coils shall be dispatched with their cores in a vertical position and an internal diameter of 420 mm.

ECCS strip is usually supplied in consignments of coils with outside diameters of at least 1 200 mm but a limited number of coils with smaller outside diameters may be included in the consignment.

The manufacturer shall state the direction of winding in the coils to ensure that the correct surface is maintained throughout manufacture. Where coils are supplied with cores vertical (the normal method of delivery), the purchaser shall specify the required direction of winding (see Figure 11).

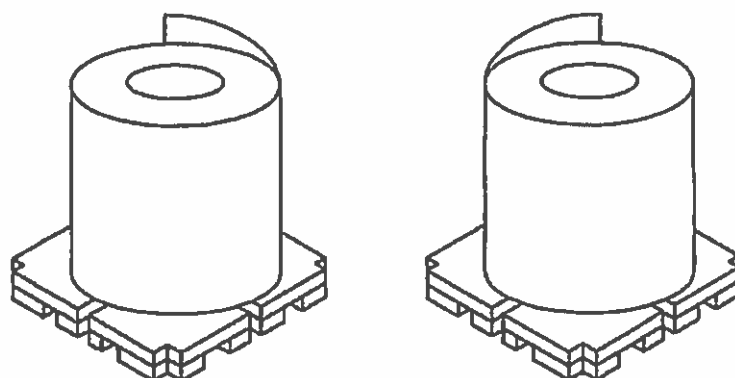

a) Anticlockwise (counterclockwise)      b) Clockwise

Figure 11 - Direction of coil winding

### 16-2 Sheets

The sheets shall be supplied in bulk packages in which the numbers of sheets are multiples of 100.

The direction of the runners of the stillage platform shall be consistent within a consignment.

The sheets are customarily packed on a stillage platform forming a bulk package weighing approximately between 1 000 kg and 2 000 kg. A limited number of bulk packages of mass with weights less than 1 000 kg may be included in a consignment.

If the purchaser has any preference for the direction of the runners of the stillage platform, his/her requirements should be agreed with the manufacturer and stated on the order. If the purchaser does not indicate his/her wish, the direction is at the discretion of the manufacturer.

### 16-3 Labelling

The products shall be marked by a label with the following items:

- a) the manufacturer's trademark or symbol;
- b) the steel grade;
- c) the dimensions;
- d) the identification number related to an appropriate inspection certificate.



**Annex A**  
(normative)  
**Hardness requirements for ECCS**

**A-1 Hardness requirement for single cold-reduced ECCS**

The hardness values for single cold-reduced ECCS shall be as given in Table A- 1, when tested as described in clause 13-2.

**Table A- 1 - Hardness values (HR30Tm) for single cold-reduced ECCS**

Steel grade		Hardness HR30Tm		
Designation	Alternative designation	Thickness <i>t</i> mm		
		$t \leq 0,21$	$0,21 < t \leq 0,28$	$0,28 < t$
T49	T-1	50 ± 4	49 ± 4	48 ± 4
T53	T-2	54 ± 4	53 ± 4	52 ± 4
T55	T-2.5	56 ± 4	55 ± 4	54 ± 4
T57	T-3	58 ± 4	57 ± 4	56 ± 4
T59	T-3.5	60 ± 4	59 ± 4	58 ± 4
T61	T-4	62 ± 4	61 ± 4	60 ± 4
T65	T-5	66 ± 4	65 ± 4	64 ± 4

**A-2 Hardness requirement for double cold-reduced ECCS**

The hardness values for double cold-reduced ECCS shall be as given in Table A- 2, when tested as described in clause 13-2.

**Table A- 2 - Hardness values (HR30Tm) for double cold-reduced ECCS**

Steel grade		Hardness HR30Tm
Designation	Alternative designation	
T71	DR-7.5	71 ± 4
T72	DR-8	72 ± 4
T73	DR-8.5	73 ± 4
T75	DR-9	75 ± 4
T76	DR-9M	76 ± 4

**Annex B**  
(normative)  
**Tensile property requirements for ECCS**

The proof strength,  $R_{p0.2}$ , for ECCS shall be as given in Table B-1, when tested as described in clause 13-3.

For routine testing, the proof strength may be determined using the springback test as described in Annex D. However, in cases of dispute, the method described in clause 13-3 shall be applied.

**Table B- 1 - Tensile properties for ECCS**

Steel grade	Annealing	$R_{p0.2}$ <sup>a</sup> MPa	Deviation <sup>b</sup> MPa
TS200	BA	200	±50
TS230	BA	230	±50
TS245	BA	245	±50
TS260	BA	260	±50
TS275	BA	275	±50
TS290	BA	290	±50
TS340	BA	340	±50
TS480	BA	480	±50
TS520	BA	520	±50
TS550	BA	550	±50
TS580	BA	580	±50
TS620	BA	620	±50
TH230	CA	230	±50
TH245	CA	245	±50
TH260	CA	260	±50
TH275	CA	275	±50
TH300	CA	300	±50
TH330	CA	330	±50
TH350	CA	350	±50
TH385	CA	385	±50
TH400	CA	400	±50
TH415	CA	415	±50
TH435	CA	435	±50
TH450	CA	450	±50
TH480	CA	480	±50
TH520	CA	520	±50
TH550	CA	550	±50
TH580	CA	580	±50
TH620	CA	620	±50
TH650	CA	650	±50

Note 1: Steel grades TS480 may be delivered in either single or double reduced form. Steel grades TS520/TH520, TS550/TH550, TS580/TH580, TS620/TH620 and TH650 are usually delivered in double reduced form only. All other grades are delivered in single reduced form.

Note 2: The deviations shown refer to measurements of individual samples.

<sup>a</sup>  $R_{eL}$  or  $R_{eH}$  may be applied for steels that show a yield point elongation by agreement between the purchaser and the manufacturer.

<sup>b</sup> In case that the deviation is out of ±50 MPa, ECCS may be supplied by agreement between the purchaser and the manufacturer.

**Annex C**  
**(Informative)**  
**Steel types**

The chemical composition of blackplate determined by cast analysis should be less than the following maximum values (% mass fraction): C: 0,13, Si: 0,03, Mn: 0,60, P: 0,020 and S: 0,030.

The following are examples of steel types:

a) steel type MR: base steel, low in residual elements that has corrosion resistance, widely used in general applications;

b) steel type L: base steel, extremely low in residual elements that has excellent corrosion resistance to certain types of food can;

c) steel type D: base steel, low in residual elements that has corrosion resistance, involving deep drawing or other types of severe forming that tend to give rise to Lueder's lines.

The choice of a suitable physical or chemical analytical method for the analysis shall be at the discretion of the manufacturer. In cases of dispute, the method for analysis used shall be agreed taking into account the relevant existing Jordanian Standards.

Note: The list of available International Standards on chemical analysis is given in ISO/TR 9769.<sup>[2]</sup>

## Annex D (Informative)

### Springback test for routine determination of proof strength for ECCS

#### D-1 General

The test described in this annex is not the reference method. In case of dispute, the method described in clause 13-3 (i.e. ISO 6892-1) shall be applied.

#### D-2 Principle

This test provides a simple and rapid means of estimating the proof strength of ECCS from measurement of thickness and angle of springback of a rectangular strip test piece, after bending through 180° around a cylindrical mandrel and then releasing.

#### D-3 Test piece

The test pieces used are identical to those for the tensile test described in clause 13-3-1.

#### D-4 Test method

Make one test on each of the test pieces obtained in accordance with clause 13-3-1 (i.e. two tests per sheet selected).

In making the test, strictly observe the operational instructions provided with the springback tester. The principal steps in the test are the following:

- a) measure the thickness of the ECCS test pieces, to the nearest 0,001 mm;
- b) insert the test piece into the tester and fix it firmly in the testing position by gently tightening the clamping screw using light finger pressure;
- c) bend the test piece through an angle of 180° around the mandrel by a gentle swing of the forming arm;
- d) return the forming arm to its "start" position and read and record the springback angle by sighting directly over the test pieces;
- e) remove the test piece from the tester and, using the recorded thickness of the test piece and the springback angle, determine the appropriate springback index value from a suitable conversion formula (e.g. Bower) agreed between the purchaser and the manufacturer.

Calibrate each new springback tester using the standard tensile test (see clause 13-3) or another "reference" springback tester. In addition, since malfunctions arising, for example, from excessive wear or inadvertent abuse of the test equipment, may not be readily apparent, it is recommended that the springback test readings should be regularly compared with readings from the standard tensile test or a "reference" springback tester. It is also recommended that such direct cross-checks be further supplemented by the frequent use of reference samples of known proof stress.

## Annex E (normative)

### Methods for the determination of metallic chromium and chromium in the oxides on the surface of electrolytic chromium/chromium oxide-coated steel

#### E-1 Determination of chromium in the oxides

##### E-1-1 Principle

This method covers the determination of chromium present as oxides and hydroxide on the surfaces of untreated ECCS. The method involves the dissolution of the oxide in sodium hydroxide followed by oxidation of the dissolved chromium with hydrogen peroxide. The absorbance of the coloured chromate ion is measured photometrically and the mass of chromium is then obtained by reference to a calibration curve.

The effective range of the method is from 3 mg/m<sup>2</sup> to 50 mg/m<sup>2</sup> and the reproducibility is better than ±3 mg/m<sup>2</sup>.

##### E-1-2 Reagents

Use reagents of analytical reagent grade, unless otherwise specified, and deionized or distilled water throughout. Freshly prepare and, where necessary, filter all solutions.

**E-1-2-1 Standard chromium solution**, dissolve 0,1132 g of anhydrous potassium dichromate, primary standard grade, previously dried at 120 °C for 1 h, in approximately 200 ml water and dilute to 500 ml in a volumetric flask. Pipette a 50 ml aliquot of this solution and dilute to 1 l with water in a volumetric flask. This solution contains 0,004 mg Cr/ml.

**E-1-2-2 Sodium hydroxide, 300 g/l solution**, dissolve 300 g of sodium hydroxide in approximately 700 ml water, cool and dilute to 1 l.

**E-1-2-3 Hydrogen peroxide, 60 g/l solution**, use a solution supplied at this concentration or dilute a concentrated (e.g. 300 g/l) solution. (Ensure that the solution is at the recommended concentration. Hydrogen peroxide solutions may decompose if kept under non-ideal conditions.)

##### E-1-3 Apparatus

**E-1-3-1 Spectrophotometer**, a spectrophotometer able to measure absorbance across the range 250 nm to 500 nm, is capable of reading extinction to ±0,001, and can produce a hard copy of the spectrum.

**E-1-3-1 Sample holder**, a sample holder of the type shown in Figure E 1, to permit stripping from an area of not less than 2 000 mm<sup>2</sup> from one surface of a sample.

##### E-1-4 Preparation of the chromium calibration curve

Pipette 0 (blank), 2,5 ml, 5 ml, 7,5 ml, 10 ml, 12,5 ml, 15 ml, 17,5 ml, 20 ml, 25 ml, 30 ml, 40 ml and 50 ml aliquots of standard chromium solution (E-1-2-1) into 400 ml beakers, add 40 ml sodium hydroxide solution (E-1-2-2) and dilute to about 90 ml with water. Add 3 ml hydrogen peroxide solution (E-1-2-3), cover with a watch glass and boil until the excess peroxide is completely decomposed, replacing any loss of evaporated water by rinsing the wall of the beaker and the cover glass. Cool the solution, transfer to a 100 ml flask, dilute to 100 ml and mix well. Measure the absorbance spectrum from 500 nm to 250 nm using a cell of appropriate length and with water as a reference. The peak of interest occurs at approximately 370 nm: draw a suitable baseline across the bottom of the spectrum, tangential to the points of minimum absorbance either side of the 370 nm peak, such that no part of the spectrum cuts the baseline and measure the maximum absorbance of the peak of interest relative to the baseline. Plot absorbance against milligrams of chromium per 100 ml, without correcting for the absorbance of the reagent blank. This plot will not necessarily pass through the origin. The drawing of a baseline across the bottom of the spectrum compensates for vertical shifting of the whole spectrum caused by interference from residual peroxide and other species not connected with the concentration of chromium.

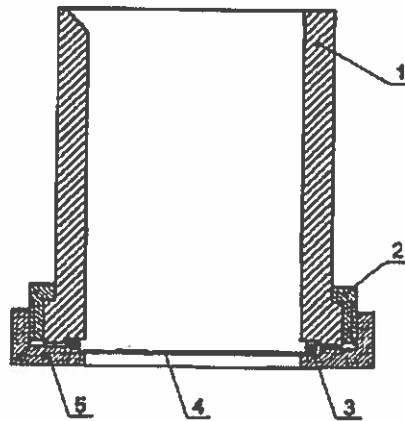

### Key

- 1:recommended wall thickness 10 mm; material: PTFE or polypropylene; cell height not critical provided capacity exceeds 120 ml and platinum cathode and reference electrode can be fitted
- 2:stainless steel stepped collar (threaded and pinned to PTFE)
- 3:rubber O-ring 3 mm diameter cross-section
- 4:sample disc 2 000 mm<sup>2</sup> exposed to solution in cell
- 5:stainless steel base plate (thread to match collar and recessed to hold sample disc)

Figure E - 1 - Dual-purpose sample holder showing details of construction

### E-1-5 Procedure

Handle sample material with care to prevent surface contamination. Do not subject samples to any thermal stoving process before carrying out the following test. Take a disc of the material appropriate to the size of the sample holder and fix it in position in the holder. Add 40 ml hot sodium hydroxide solution (E-1-2-2) and place the cell on a hot plate to maintain the temperature of the stripping solution at about 90 °C for 10 min. Transfer the contents of the cell quantitatively to a 250 ml beaker, add 3 ml of hydrogen peroxide solution (E-1-2-3) and boil until the excess peroxide is decomposed. Cool, transfer to a 100 ml volumetric flask, make up to the mark with water and shake well. Measure the absorbance between 500 nm to 250 nm (E-1-4) using water as a reference. Draw a baseline across the bottom of the spectrum as before and measure the maximum absorbance of the peak at approximately 370 nm, relative to this baseline. Obtain the mass of chromium in mg in the solution from the calibration curve.

### E-1-6 Calculation

Calculate the coating mass in mg/m<sup>2</sup> of chromium in the oxide,  $C_o$ , from Formula (E-1):

$$C_o = \frac{M_1}{A} \times 10^6 \quad (\text{E-1})$$

where

$M_1$ : is the mass of chromium, in milligrams, in the test solution;

$A$  : is the area of sample, in square millimetres, exposed to sodium hydroxide attack in the sample holder.

## E-2 Determination of metallic chromium

### E-2-1 Principle and scope of method

A photometric method is described for the determination of metallic chromium on the surface of ECCS. The principles of the method are as follows.

Chromium oxide is first removed chemically. Metallic chromium is then stripped electrolytically in sodium carbonate solution, the completion of the reaction being indicated by a sharp rise in the cell voltage. The resultant solution is treated with hydrogen peroxide to ensure complete oxidation of the electrolytically stripped chromium to the hexavalent state. The absorbance of the coloured

chromate ion is determined photometrically and the mass of chromium is then obtained by reference to a calibration curve.

The effective range of the method is from 30 mg/m<sup>2</sup> to 300 mg/m<sup>2</sup> and the reproducibility is better than ±5 mg/m<sup>2</sup>.

#### E-2-2 Reagents

Use reagents of analytical grade, unless otherwise specified, and deionized or distilled water throughout. Freshly prepare and, where necessary, filter all solutions.

**E-2-2-1 Standard chromium solution**, dissolve 1,132 g anhydrous potassium dichromate, primary standard grade, previously dried at 120 °C for 1 h, in approximately 200 ml water and dilute to 1 l in a volumetric flask. Pipette a 50 ml aliquot of the solution and dilute to 1 l in a volumetric flask. This solution contains 0,02 mg Cr/ml.

**E-2-2-2 Sodium hydroxide, 300 g/l solution**, dissolve 300 g sodium hydroxide in approximately 700 ml water. Cool and dilute to 1 l.

**E-2-2-3 Sodium carbonate, 53 g/l solution**, dissolve 53 g anhydrous sodium carbonate in water and dilute to 1 l.

**E-2-2-4 Hydrogen peroxide, 60 g/l solution**, use a solution supplied at this concentration or dilute a concentrated (e.g. 300 g/l) solution. (Ensure that this solution is at the recommended concentration. Hydrogen peroxide solutions may decompose if kept under non-ideal conditions.)

#### E-2-3 Apparatus

**E-2-3-1 Cell and electrodes**, a cell as shown in Figure E - 2 for the electrolytic stripping of the metallic chromium. As shown in Figure E - 3 and consisting of a sample holder, a platinum gauze cathode and a reference electrode (standard calomel).

The cell/sample holder exposes a minimum area of 2 000 mm<sup>2</sup> from which the metallic chromium is electrolytically stripped.

**E-2-3-2 Power supply**, with direct current stabilizer with a built-in milliammeter setting to 30 mA and an on/off switch.

**E-2-3-3 Voltmeter**, with a full scale of 0 V to 2 V.

**E-2-3-4 Spectrophotometer**, able to measure absorbance in the range 250 nm to 500 nm and read extinction to ±0,001 and can produce a hard copy of the spectrum.

#### E-2-4 Preparation of the chromium calibration curve

Pipette 0 ml (blank), 2,5 ml, 5 ml, 7,5 ml, 10 ml, 12,5 ml, 15 ml, 17,5 ml, 20 ml, 25 ml, 30 ml, 40 ml and 50 ml of the standard chromium solution (E-2-2-1) into 400 ml beakers, add 120 ml of sodium carbonate solution (E-2-2-3) and dilute to about 170 ml with water. Add 10 ml hydrogen peroxide solution (E-2-2-4), cover with a watch glass and boil until the excess peroxide is completely decomposed, replacing any loss of evaporated water by rinsing the wall of the beaker and the cover glass. Cool the solution, transfer to a 200 ml flask, dilute to the mark and mix well. Measure the absorbance spectrum from 500 nm to 250 nm using a cell of suitable length and with water as a reference. The peak of interest occurs at approximately 370 nm: draw a suitable baseline across the bottom of the spectrum, tangential to the points of minimum absorbance close to each end of the spectrum and measure the maximum absorbance of the peak of interest relative to this baseline. Plot absorbance against milligrams of chromium per 200 ml, without correcting for the absorbance of the reagent blank. This plot will not necessarily pass through the origin.

#### E-2-5 Procedure

##### E-2-5-1 General

Handle sample material with care to prevent surface contamination. Do not subject samples to any thermal stoving process before carrying out the following test. Take a disc of the material appropriate to the size of the sample holder.

It is normal procedure to determine metallic chromium after determining the chromium in the oxide and the same sample discs may be used for both purposes. Where metallic chromium is to be

determined without a previous determination of chromium in the oxide, remove the chromium oxide in accordance with E-2-5-2.

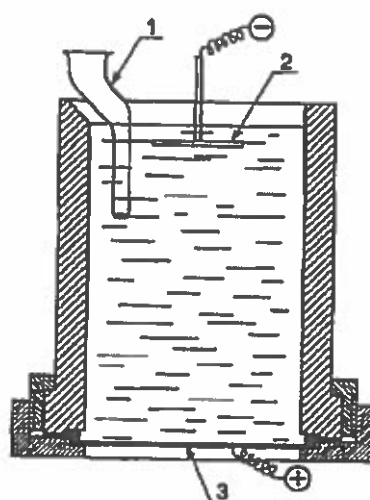

**Key**  
 1:reference electrode  
 2:platinum cathode  
 3:sample (anode)

**Figure E - 2 - Electro-stripping of chromium metal using the dual-purpose cell**

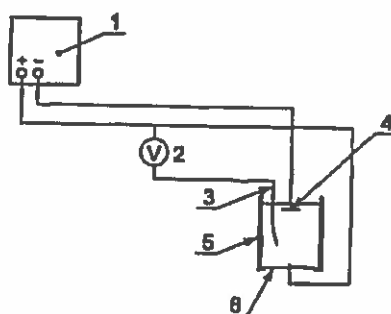

**Key**  
 1: DC stabilizer, 30 mA  
 2: voltmeter 0 V to 2 V  
 3: reference electrode  
 4: platinum cathode  
 5: sample holder  
 6: sample (anode)

**Figure E - 3 - Electro-circuit for stripping chromium metal**

#### E-2-5-2 Removal of chromium oxide layer

Remove the surface oxides from the sample by treating with 40 ml of sodium hydroxide solution (E-2-2-2) in a glass beaker at 90 °C for 10 min. Rinse the sample with water and attach to the sample holder (see Figure E - 1).

#### E-2-5-3 Removal and determination of metallic chromium

After the washed, oxide-free sample (E-2-5-2) has been attached to the sample holder, connect the leads as shown in Figure E.3 add 120 ml of sodium carbonate solution (E-2-2-3) and simultaneously switch on the power supply. Maintain a constant current density within the range 0,5 mA/cm<sup>2</sup> to 1,5 mA/cm<sup>2</sup>. The end point of the reaction is indicated by a large potential jump. (The potential difference between the beginning and ending of the dissolution is about 400 mV. Note this by



incorporating in the electrical circuit a voltmeter with the positive terminal connected to the DC stabilizer and the negative terminal to the reference electrode.)

Quantitatively transfer the contents of the sample holder/cell to a glass beaker, add 10 ml of hydrogen peroxide solution (E-2-2-4) and boil until the excess peroxide is decomposed. Cool the solution, transfer to a 200 ml flask, dilute to the mark with water and mix well.

Measure the absorbance spectrum between 500 nm to 250 nm (E-2-4) using water as a reference. Draw a baseline across the bottom of the spectrum as before and measure the maximum absorbance of the peak at approximately 370 nm, relative to this baseline. Obtain the mass of chromium in mg in the solution from the calibration curve.

#### E.2.6 Calculation

Calculate the coating mass in mg/m<sup>2</sup> of metallic chromium,  $C_m$ , from Formula (E-2):

$$C_m = \frac{M_2}{A} \times 10^6 \quad (E-2)$$

where

$M_2$ : is the mass of chromium, in milligrams, in the test solution;

$A$  : is the area of sample, in square millimetres, exposed to electrolytic attack in the sample holder/cell.

**Annex F**  
(normative)

**Rockwell HR15Tm values and their HR30Tm equivalents**

**Table F - 1 - Rockwell HR15Tm values and their HR30Tm equivalents**

HR15Tm value	Equivalent HR30Tm value	HR15Tm value	Equivalent HR30Tm value
93,0	82,0	83,0	62,5
92,5	81,5	82,5	61,5
92,0	80,5	82,0	60,5
91,5	79,0	81,5	59,5
91,0	78,0	81,0	58,5
90,5	77,5	80,5	57,0
90,0	76,0	80,0	56,0
89,5	75,5	79,5	55,0
89,0	74,5	79,0	54,0
88,5	74,0	78,5	53,0
88,0	73,0	78,0	51,5
87,5	72,0	77,5	51,0
87,0	71,0	77,0	49,5
86,5	70,0	76,5	49,0
86,0	69,0	76,0	47,5
85,5	68,0	75,5	47,0
85,0	67,0	75,0	45,5
84,5	66,0	74,5	44,5
84,0	65,0	74,0	43,5
83,5	63,5	73,5	42,5

**Annex G**  
**(Informative)**  
**Bibliography**

- [1] ISO 11951, *Cold-reduced tinmill products — Blackplate*  
[2] ISO/TR 9769, *Steel and iron — Review of available methods of analysis*